

Performance of Modular PFC Boost Converter using Average Current Control Technique for improving EMI

Syed Mujtaba Mahdi Mudassir¹ Gulam Amer² Shaik Mohammed Mukassir³

Abstract-The modular power system is best suited for high power applications and high power is achieved by paralleling multiple small power stages in a single package. In this paper, proposed PWM active clamped boost converter in modular approach is compared with other topologies. The modular converters operating in continuous conduction mode allow high power factor and less EMI. Both modular boost converter topologies use average current control technique and operates in continuous conduction mode where as full-bridge converter operates in discontinuous conduction mode. The proposed converter maintains an input power-factor almost unity, regulated output voltage and improved efficiency of 92% when compared with the other boost derived topologies. Control circuit used is average controller IC UC3854. High power factor is achieved using the proposed converter. The simulation results of different boost converter topologies are presented and compared.

Keywords-Modular converters, active clamp, power factor correction, Boost converter, Full-bridge converter and soft switching.

I. INTRODUCTION

Motivated by the forthcoming stringent power- quality regulations, power-factor correction (PFC) has been an active research topic in power electronics. The single phase PFC is already a common practice, and the industrial application of three-phase PFC techniques has also emerged. Up to this point, the research of three-phase converters has been heavily focused on inverter applications. Although most techniques developed in the inverter area can be used in PFC applications, a PFC circuit has its unique characteristics and, therefore, deserves some special treatment. The primary differences between PFC and inverter applications include the following aspects. Special attention has to be paid to the quality of input current to reduce the pollution to the utility, usually measured by the input current total harmonic distortion (THD). Although there are no specific limits on the input current distortion of general high-power three-phase converters at present, it is a common practice to limit the input current THD of three-phase PFC converters at least below 10%. This makes control design more critical than in inverters.

Efforts on reducing power harmonics have led to the development of some new "power factor correction (PFC) circuits which draw almost pure sinusoidal current from the AC power supply in the AC-DC power conversion process. The technique used is to control the switching action of the PFC circuit so that the input line current

is shaped into a sinusoidal waveform. Because the input current is near- sinusoidal, the amount of harmonics is small and can be filtered easily. Harmonics pollution can thus be minimized. For three-phase AC-DC power converters with step-down ability some investigations concentrate on the novelty of new topology, theory and operation of the converters, whilst reports from industry prefer to extend existing and well proven single-phase technology to the development of high power systems. This modular approach has recently been tested with boost converters. The industry-preferred approach favors the paralleling of single-phase converter units to form high-power converter systems. Such modular development approach has the following advantages:

- well proven and reliable single-phase converter technology can be used immediately,
- no major change of existing production line is required,
- power expandability offers great flexibility in the development of power converter products for different power levels, less requirements for maintenance and repair of power converter modules because of the use of standard single-phase converter units,
- Standard single-phase converter units do not require high-voltage devices that are normally needed in specially designed three-phase converters.

II. STATE ART

Usage of power electronic (PE) converters is ever increasing in the processing of electrical energy in industrial applications such as adjustable speed drives (ASD), SMPSs, UPSs, etc [1]. Therefore, the converters with high power factor are increasingly required in industries. In high-power range, mainly a three-phase system is employed.

Most of the PE systems which get connected to ac utility mains use diode rectifiers at the input [2].The active power line conditioners (APLCs) used for harmonic reduction are generally hard switched; hence, the components are subjected to high-voltage stresses which increases further with increase in the switching frequency. Also, hard switching results in low efficiency, large EMI, etc. as discussed in [3]. In soft-switched resonant converters, some of their characteristics such as large conduction losses, high component stresses, load limitation, and high cost restrict the practical use of these converters as discussed in [4]. Such converters are usually operated in variable frequency mode, and thus components are required to be designed at the lowest operating frequency. Also, resonant tank circuits are required to be designed at a much higher kVA/kW rating. The active clamp technique is one of the most attractive zero voltage- switching (ZVS) topologies [5], [6]. Medium and high power acdc converters usually make use of continuous conduction mode (CCM) boost topology as it gives near to unity

The paper first received 30 Nov 2017 and in revised form 06 July 2018.
Digital Ref: APEJ-2017-11-0523

^{1,3}Department of Electrical & Electronics Engineering, Engineering Deccan College of Engineering & Technology, Darusalaam, Hyderabad-01,Telangana, India, (Email: smmmudassir@yahoo.co.in)

²Department of Electronics & Instrumentation, Engineering Deccan College of Engineering & Technology, Darusalaam, Hyderabad-01,Telangana, India,

power factor (UPF) at the AC input [7].

Industries are focusing on extension of existing and well-proven single-phase technology for the development of high power converters. A modular approach provides a convenient paralleling of modules, thus facilitating power expandability. Modules being identical, reserve inventory requirement, manufacturing cost, and time are also reduced. It would also reduce a problem like arduous heat dissipation and expensive components of high rating which may occur in single high power design [8]. The parallel operations of the modular design for boost-type power factor correction circuits are presented in [9]. A near unity power factor of the ac input along with a well regulated dc output voltage is obtained by constant-frequency variable duty-ratio control. By operating the inductors at DCM operation, not only the switching loss is reduced, but also balanced current sharing is achieved by controlling equal duty-ratio for all modules. The frequency of the input current ripple is increased, and its magnitude is reduced by phase-shift control. Phase shift control circuit is used to generate the gate signals for active power switches of operating parallel modules.

Modular approach is also presented in [10]. The main characteristics of the proposed system are: its modularity, the employment of simple and well-known techniques, high quality of the input currents and of the output voltage, good efficiency and possibility of continuity in the operation with fall of phase or module fail. The rectifier unit is composed of three single-phase modules without neutral connection and independent power factor pre-regulation stages. The same current in each module is ensured by the current mode control technique. In [11], there exist interactions between different modules which causes boost inductor current of the same module to be different during the off interval of the main switches. In this a 3-Ph rectifier employing three 1-Ph boost PFC circuits is analyzed. Each converter operates in continuous conduction mode. ZVT technique is applied to each converter, to obtain zero turn-on losses and soft turnoff of the freewheeling diodes. Current sharing is ensured by common voltage loop driving individual current loops of 3-converter. Each converter works in CCM. To limit interaction among phases suitable modifications made. Analysis of converter in star and delta connections is analyzed.

In the converter [12], no such interaction takes place between modules. In this paper, a three-phase acdc converter with input power factor almost unity and soft-switching topology in modular approach is presented. An identical single-phase boost type active clamped acdc converter is connected in each line of a three-phase AC source. Outputs of all the three converter modules are connected in parallel to raise the power level. As a separate PFC-PWM controller is provided for each module, the independent control is facilitated even under unbalanced input voltages. The PFC-PWM controllers are not very costly; therefore, increase in the cost is marginal. A comparative performance of resonant, soft switched and hard switched 1-ph PFC rectifier circuits for telecommunication applications is presented in [13]. In this resonant rectifier has higher efficiency than other two rectifiers. Soft switched rectifier uses a phase-shift modulation technique. Resonant rectifier is similar to soft switch rectifier circuit except that it uses a resonant circuit at the output of full-bridge. The Boost pre-regulator used for PFC uses avg. current control technique, to achieve high input P.f. The modular development of single-stage AC-DC power converters is presented in [14]. Features are simple switching control, electrically isolated output, inherent PFC, flexibility for expansion of power capability and a simplification of design.

DC characteristics of the three-phase modular power-factor-correction (PFC) converters using single-phase pulse width modulation (PWM) dc-to-dc converter modules for high-power application are studied in [15]. A single-stage three-phase PFC circuit is developed using three isolated single-phase SEPIC-based PFC circuits operating

in continuous-current mode [16]. This approach is found to be attractive for low to medium power applications. Use of isolated single-phase circuits also avoids the problems associated with the interaction among three phases. Detailed design criteria for the power and control stages of the single-phase SEPIC power-factor-correction circuit are presented. Issues specific to the three-phase implementation, such as current sharing at the input, are discussed. The three single-phase modules are connected in delta at the input and in parallel at the output. The individual modules have independent average-mode current controllers driven by a common outer voltage loop.

A single-stage PFC ac/dc converter based on ZVS full bridge topology with two series-connected transformers is proposed in [18]. The converter offers a very wide ZVS range due to the configuration of two series-connected transformers, without auxiliary circuits by just complementarily controlling the duty ratio of switches. High efficiency over wide load ranges, high Pf, low input current harmonics. Integrating the boost stage operated in the DCM in order to achieve the PFC. The steady state equations have been derived according to the large signal modelling. The practical aspects of building modular power supply for telecom application are described in [19]. A single-ended PWM three-phase rectifier is presented in, which is capable of high power factor and wide output voltage regulation while using high-frequency transformer insulation. A single-stage 3-phase AC-DC step-down converter without neutral connection is presented in. In this paper, the modular approach allows well-established singlephase converter modules to be paralleled to form high-power 3-phase converters. The modular approach allows well-established singlephase converter modules to be paralleled to form high-power three-phase converters. This approach greatly enhances the flexibility and power expansibility of power converters and significantly simplifies the production and maintenance procedures of such power products. The transfer function of the modular system is similar to that of a DC-DC converter. In addition, all switches in the modules are controlled simultaneously. Thus, the AC-DC modular system can be controlled as if it is a DC-DC converter. With the development of soft-switching technique, the proposed modular converter approach offers an alternative solution for reducing both low and high frequency EMI emission from power converter systems.

III. PROPOSED MODULAR PFC BOOST CONVERTER

Fig. 1 shows simplified block-diagram of a three-phase acdc converter in a modular system. Fig. 2 shows circuit diagram of the proposed single-phase module. The proposed converter consists of a small line filter comprising of L_f and C_f followed by single-phase line rectifier ($D_1 - D_4$) and a very small high-frequency bypass capacitor C_{in} . Unlike the conventional boost converter, in addition to the boost inductor L_b and the high-frequency (HF) rectifier output diode D ; the resonant inductor L_r in series and resonant capacitor C_r in parallel are connected to the main switch S_m . The auxiliary switch S_a with series connected clamping capacitor C_c is connected between the drain of the S_m and the cathode of the D . The small capacitor C_n is used as a high-frequency bypass filter at the output of each module. Both the switches are driven in a complementary manner. The single output filter capacitor C_o is used at the output of the three-phase.

By sensing boost inductor current, output dc and input ac voltages, gating pulses are generated accordingly using PFC-PWM IC (UC3854) and fed to Driver IC (UC3706). Drive IC provides complementary gate drive pulses with sufficient dead band. A PCB-mounted miniature current LEM is used for sensing the boost inductor current. When boost inductor current exceeds the set limit, drive pulses are disabled, hence the converter is protected. Proposed converter uses average current mode control. In average current mode control, boost inductor current is continuously monitored

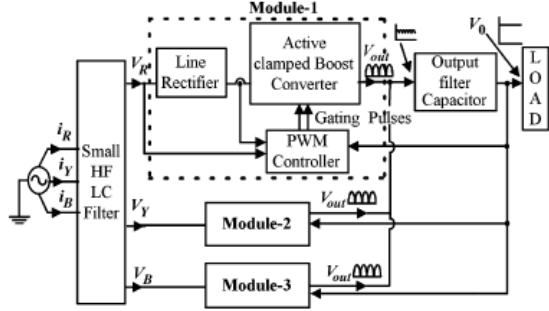

Fig. 1: Three-phase modular converter system

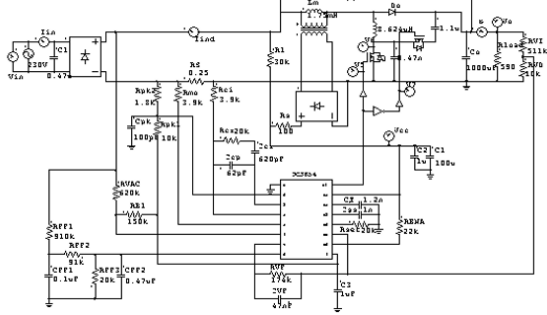

Fig. 2: Simulation circuit of proposed boost topology-1

and controlled to follow the reference signal proportional to ac line voltage. Thus, input current is sinusoidal. To regulate output voltage, a multiplier circuit controls the amplitude of the sinusoidal current reference signal in accordance with the voltage error signal generated using the output voltage and rectified input ac voltage. When the load decreases, the output voltage increases. To maintain constant load voltage, the control circuit senses the load voltage and the pulse width is automatically reduced in the switching cycle and the output voltage is regulated and maintained almost constant. The control circuit varies the duty ratio in switching cycles over the input supply voltage cycle, as the instantaneous input supply voltage is varying over the cycle.

IV. DESIGN OF MODULAR CONVERTERS

A. Proposed Boost Converter Topology-1

From different modes of operation of circuit, we get the following equations:

$$i_{L_b}(t) = i_{L_b}(t_0) + \frac{(V_{in} - V_o)(t - t_0)}{L_b} \quad (1)$$

$$i_{L_b}(t) = i_{L_b}(t_1) + \frac{(V_{in} - V_o)(t - t_1)}{L_b} \quad (2)$$

$$i_{L_b}(t_3) = i_{L_b}(t_3) \approx \frac{V_{in}(D_m - D_s)T}{L_b + L_r} \quad (3)$$

$$i_{L_b}(t) = i_{L_b}(t_4) + \frac{(V_{in} - V_o)(t - t_4)}{L_b} \quad (4)$$

$$i_{L_b}(t) = i_{L_b}(t_5) + \frac{(V_{in} - V_o)(t - t_5)}{L_b} \quad (5)$$

Neglecting transition intervals between two switches and based on voltage-second balance of the boost inductor L_b , from (1)(3) and

(4) and (5); we get

$$\frac{V_{in} - V_o}{L_b}(D_s) + \frac{V_{in}}{L_b + L_r}(D_m - D_s) + \frac{V_{in} - V_o}{L_b}(1 - D_m) = 0$$

Therefore, output voltage is given by,

$$V_o = \frac{V_{in}}{1 - D_m + D_s} \left[1 - \frac{L_r}{L_b + L_r}(D_m - D_s) \right]$$

If $L_b \gg L_r$ and $D_m \gg D_s$, we get $V_o \approx \frac{V_{in}}{1 - D_m}$.

If peak to peak ripple current of the boost inductor $L_b = \Delta I_{L_b}$, $\Delta I_{L_b} \approx i_{L_b}(t_4) - i_{L_b}(t_2)$, Neglecting D_s interval

$$\Delta I_{L_b} \approx \frac{V_{in}}{L_b + L_r} D_m T$$

From above two equations we get,

$$\Delta I_{L_b} \approx \frac{V_o}{L_b}(1 - D_m)D_m$$

$$L_b \approx \frac{V_o}{\Delta I_{L_b} f_s}(1 - D_m)D_m$$

L_b will be maximum for $D_m = 0.5$. L_b should be greater than the value calculated by above equation at $D_m = 0.5$; therefore, minimum value of boost inductor (L_{bmin}) is,

$$L_{bmin} = \frac{V_o}{4\Delta I_{L_b} f_s}$$

Energy stored in the resonant inductor L_r must be greater than the energy stored in the resonant capacitor C_r to achieve ZVS for the main switch S_m . Thus,

$$L_r \geq \frac{C_r(V_o + V_{cc})^2}{(i_{L_r}(t_6))^2}$$

At the end of Mode 7, the resonant capacitor C_r discharges to zero in the quarter cycle of the resonant frequency $\omega_3 = \frac{1}{\sqrt{L_r C_r}}$, thus, the time required for discharging C_r completely is given by $t_d = (\frac{\pi}{2} \sqrt{L_r C_r})$, thus, $L_r = \frac{4t_d^2}{\pi^2 C_r}$.

By choosing a suitable value of C_r and t_d , the required value of L_r can be found out.

The duration required to reach to $V_{cc(max)}$ is approximately one half of the off period of the main switch, thus V_{cc} can be expressed as

$$V_{cc} \approx L_r \frac{2I_{L_r}}{(1 - D_m)T} \approx 2L_r f_s \frac{V_o^2}{V_{in}} I_o$$

Where f_s is the switching frequency Peak-to-peak ripple voltage of clamp capacitor ΔV_{cc} can be expressed as

$$\Delta V_{cc} \approx \frac{1}{C_o} \int_0^{[(1-D_m)/2]T} i_{L_r} dt \approx \frac{I_o}{4C_o f_s}$$

If $\Delta V_{cc} = kV_{cc(max)}$ the value of clamp capacitor C_c can be obtained as

$$C_c = \frac{(V_{in(min)})^2}{8kL_r f_s^2 V_o^2}$$

The value of the output filter capacitor C_o is dependent on allowable peak-to-peak value of output voltage ripple V_{p-p} and maximum

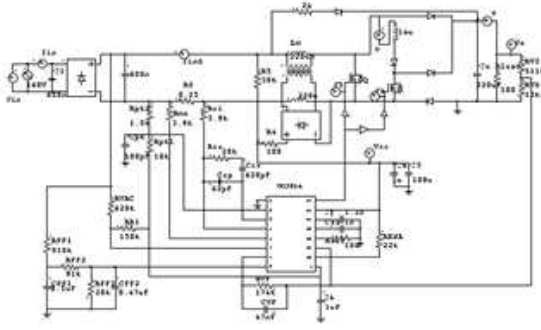

Fig. 4: Single-phase simulation circuit of boost topology-2

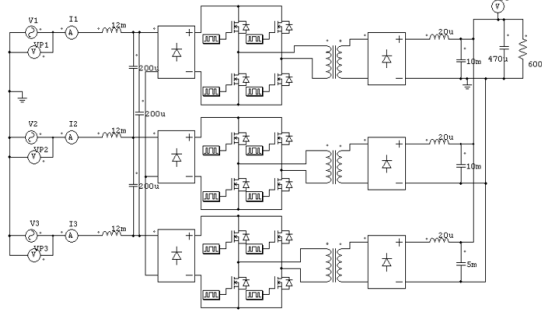

Fig. 6: Three-phase simulation circuit of boost topology-2

load current I_o and input line frequency f and is given by

$$C_o = \frac{2(2I_o/35)}{6\omega V_{p-p}} = \frac{I_o}{105\pi f V_{p-p}}$$

B. boost Converter Topology-2

Besides the ZVT network composed by L_r , D_r and S_r , each circuit differs from the normal boost topology by the presence of a split input inductor L_{ja} , L_{jb} and a split freewheeling diode D_{ja} , D_{jb} ($j=1,2,3$). Input voltage of 160V, 50Hz is given. Power rating is 500W. Control circuit UC3854 is shown. Three phase modular connection of boost topology-2 is shown in Fig. 5 Three-single phase modules are connected in parallel.

C. Full-Bridge Modular Circuit

A simulation diagram of Full-Bridge modular converter is shown in Fig. 6 Input voltage = 160V, Output power = 1500W, Output voltage = 500V. Inputs are star connected and outputs are paralleled.

V. SIMULATION RESULTS

Proposed boost converter topology-1, boost converter topology-2 and Full-Bridge converters are simulated for three phase in modular approach. Control circuit used is UC3854 PFC IC, which uses average current control technique. Output voltage, rectified input voltage and rectified input current are taken as reference values to the control circuit. Simulation is done for the following specifications:

- for 3-phase circuit: Input voltage=400V (rms), 50 Hz, Output voltage=500V, Output Power=1500W,
- for 1-phase circuit: Input voltage=160V (rms), 50 Hz, Output voltage=500V, Output Power=500W.

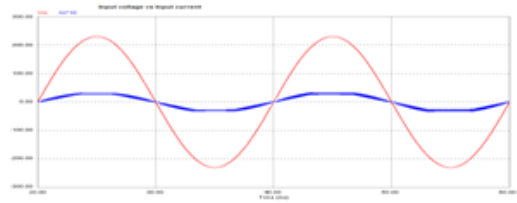

Fig. 7: Input Voltage and current waveforms of 1-ph circuit

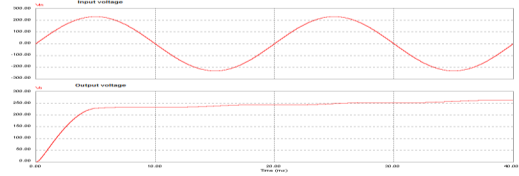

Fig. 8: Input and Output voltage waveforms of 1-ph circuit

A. Simulation of Boost Converter Topology-1

Fig. 7 shows single phase input voltage vs current waveforms. There is no phase difference between current and voltage thus, input power-factor is almost unity.

Fig. 8 shows single phase input voltage vs output voltage. It is observed that the output voltage is almost constant DC and does not have many disturbances. Fig. 9 shows 3 phase input voltages and input currents and output voltage of boost topology-1. AC input line currents follow their input voltages; thus, input power-factor is almost unity. Output voltage is almost constant DC.

B. Simulation of Boost Converter Topology-2

Fig. 10 shows 3 phase input voltages and input currents of boost topology-2. It is observed that ac input line currents are little phase-shifted with respect to sinusoidal input voltages thus, input power-factor is less compared to boost topology-1.

C. Simulation of Full-Bridge Modular Converter

Fig. 11 shows 3 phase input voltages, input currents and output voltage of Full-Bridge modular converter. The input currents follow

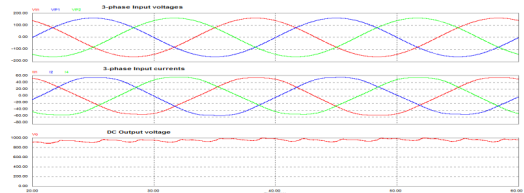

Fig. 9: Input and Output voltage waveforms of 1-ph circuit

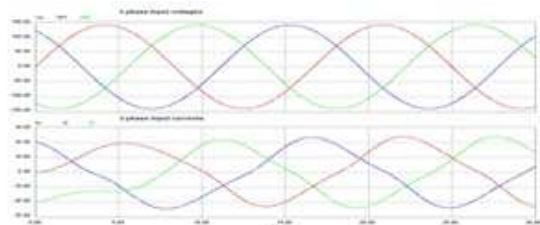

Fig. 10: Input and Output voltage waveforms of 1-ph circuit

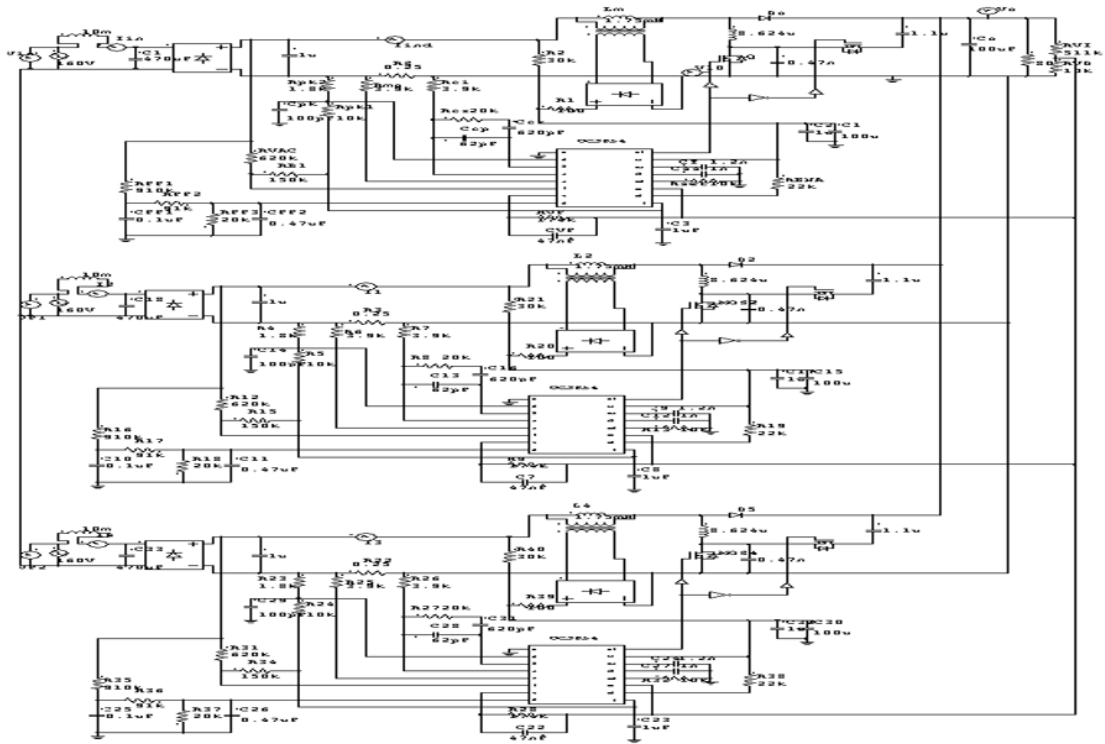

Fig. 3: Three phase circuit diagram of proposed boost converter topology 1

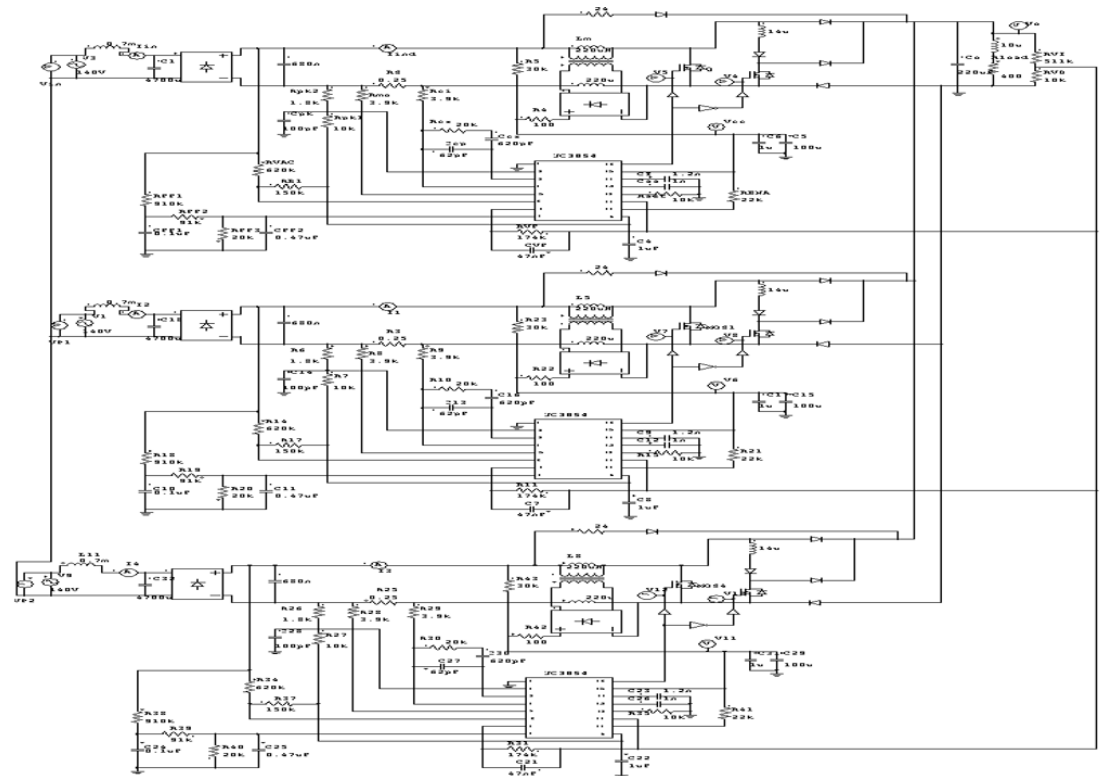

Fig. 5: Three-phase simulation circuit of boost topology-2

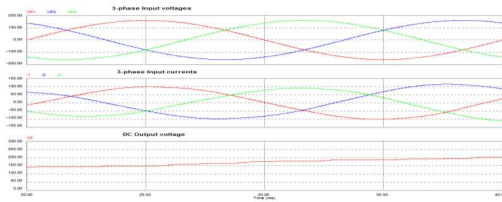

Fig. 11: Input and Output voltage waveforms of 1-ph circuit

input voltages but not exactly. Power factor is less than boost topology-1 and almost same as that of boost topology.

VI. CONCLUSION

Three-phase acdc converter using three single-phase dc-dc converters in modular approach is studied. Proposed boost converter topology-1 in modular approach is compared with other topologies. For proposed boost topology, P.f=0.99 and THD=7.8 for 1-Ph and P.f=0.99 and for 3-Ph P.f=0.99, 0.98, 0.99 and THD=5.56%, 12.9% and 4.5% respectively for 3-Ph currents. For other topologies Power factor is less and THD more compared to proposed topology. Efficiency is highest for proposed topology. It is found that efficiencies are 92%, 90% and 88% and power factors are around 0.99, 0.9 and 0.89 respectively for proposed boost topology-1; boost topology-2 and full-bridge converters.

Boost topology is better than other topologies as it operates in Continuous conduction mode and has highest power factor compared to others. Control circuit used is UC3854 PFC which uses average current control technique to control the pulses. Boost topology has less number of switches compared to others. It operates at almost unity power factor, low THD, and high efficiency and less number of components. As number of switches is more in Full-Bridge converter, switching losses are more in it compared to other converter topologies. The only disadvantage in boost converter is high output voltage, which is to be stepped down, as low voltages are required in telecommunication applications.

REFERENCES

- [1] B. Singh, B. N. Singh, A. Chandra, K. Al-Haddad, A. Pandey, and D. P. Kothari, "A review of three-phase improved power quality acdc converters," *IEEE Trans. Ind. Electron.*, vol. 51, no. 3, pp. 641660, Jun, 2004.
- [2] B. M. Saied and H. I. Zynal, "Minimizing current distortion of a three-phase bridge rectifier based on line injection technique," *IEEE Trans. Power Electron.*, vol. 21, no. 6, pp. 17541761, Nov, 2006.
- [3] M. R. Ramteke, H. M. Suryawanshi, and K. L. Thakre, "Single-phase resonant converter in three-phase system in modular approach," *EPE J*, vol. 16, no. 4, pp. 513, Dec, 2006.
- [4] T.-F. Wu and S.-A. Liang, "A systematic approach to developing single-stage soft switching PWM converters," *IEEE Trans. Power Electron.*, vol. 16, no. 5, pp. 581593, Sep, 2001.
- [5] R. Watson, F. C. Lee, and G. C. Hua, "Utilization of an active clamp circuit to achieve soft switching in flyback converters," *IEEE Trans. Power Electron.*, vol. 11, no. 1, pp. 162169, Jan, 1996.
- [6] J. A. Cobos, O. Garcia, J. Uceda, J. Sebastian, and E. Cruz, "Comparison of high efficiency low output voltage forward topologies," *Proc. IEEE PESC*, pp. 887894, 1994.
- [7] M. M. Jovanovic, "A technique for reducing rectifier reverse recovery related losses in high power boost converter," *IEEE Trans. Power Electron.*, vol. 13, no. 5, pp. 932941, Sep, 1998.
- [8] R. Ayyanar, R. Giri, and N. Mohan, "Active input voltage and load current sharing in input-series and output parallel connected modular dc-dc converter using dynamic input-voltage reference scheme," *IEEE Trans. Power Electron.*, vol. 19, no. 6, pp. 14621473, Nov, 2004.
- [9] C. S. Moo, H. L. Cheng, and P. H. Lin, "Parallel operation of modular power factor correction circuits," *IEEE Trans. Power Electron.*, vol. 17, no. 3, pp. 398404, May, 2002.

- [10] M. L. Heldwein, A. Ferrari de Souza, and I. Barbi, "A simple control strategy applied to three-phase rectifier units for telecommunication applications using single-phase rectifier modules," *Proc. IEEE PESC*, pp. 795800.
- [11] G. Spiazzi and F. C. Lee, "Implementation of single-phase boost power-factor correction circuits in three-phase applications," *IEEE Trans. Ind. Electron.*, vol. 44, no. 3, pp. 365371, Jun, 1997.
- [12] H. M. Suryawanshi, Member, IEEE, M. R. Ramteke, K. L. Thakre, and V. B. Borghate, "Unity-Power-Factor Operation of Three-Phase AC DC Soft Switched Converter Based On Boost Active Clamp Topology in Modular Approach," *IEEE Trans. Power Electron.*, vol. 23, no. 1, Jan, 2008.
- [13] Praveen Jain, Jim Valerio and Pankaj Jain, "A Review of Single Phase Power Factor Correction Circuits For Telecommunication Applications," *16th International Telecommunications Energy Conference, INTELEC*,
- [14] S.Y.R. Hui, H. Chung, Y.K.E. Ho and Y.S. Lee', "Modular development of single-stage 3-phase pfc using single-phase step-down converters," *29th IEEE Power Electronics Specialists Conference, PESC 98*, vol. 1.
- [15] Y. K. Eric Ho, S. Y. R. Hui, and Yim-Shu Lee, "Characterization of Single-Stage Three-Phase Power-Factor-Correction Circuit Using Modular Single-Phase PWM DC-to-DC Converters," *IEEE Trans. Power Electron.*, vol. 15, no. 1, Jan, 2000.
- [16] Rajapandian Ayyanar and Ned Mohan, "Single-Stage Three-phase Power-Factor-Correction Circuit Using Three Isolated Single-phase SEPIC Converters Operating in CCM," *31st Power Electronics Specialists Conference, PESC 2000 IEEE*, vol. 1.
- [17] Sewan Choi and Youngsang Bae, "A New Unity Power Factor Telecom Rectifier System by an Active Waveshaping Technique," *Industry Applications Conference, Fourtieth IAS Meeting. Conference Record 2005*, vol. 2.
- [18] Tae-Sung Kim, Gwan-Bon Koo, Gun-Woo Moon, and Myung-Joong Youn, "A Single-Stage Power Factor Correction AC/DC Converter Based on Zero Voltage Switching Full Bridge Topology With Two Series-Connected Transformers," *IEEE Trans. Power Electron.*, vol. 21, no. 1, Jan, 2006.
- [19] T. Thandapani and R. Arumugam, "Modular Power Supply for Telecom Application (54V/100A)," *IEEE ISIE 2006, Montreal, Quebec, Canada*, pp. 9-12, July, 2006.